

PART NO. CA-U709089-X.XM

REVISIONS				
LTR	DESCRIPTION	DATE	APPROVED	
A	INITIAL RELEASE SEE DO 6681	CP 06-24-08	A.J.	

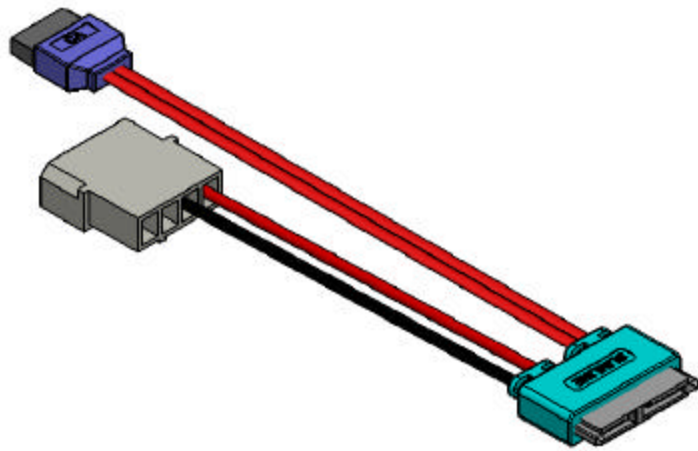

2 3 WIRING DIAGRAM :

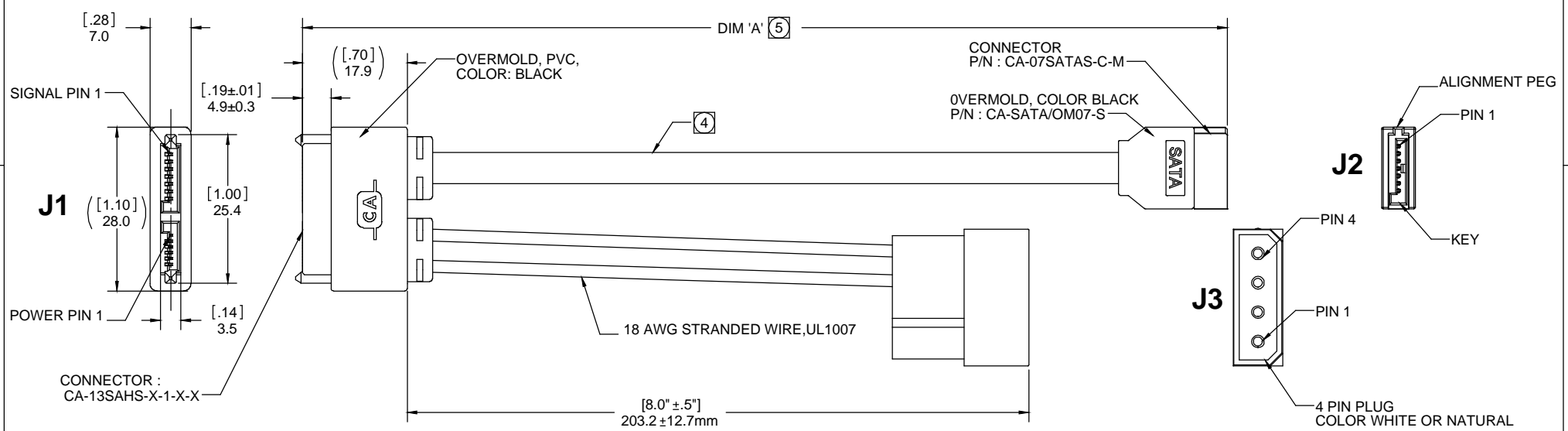
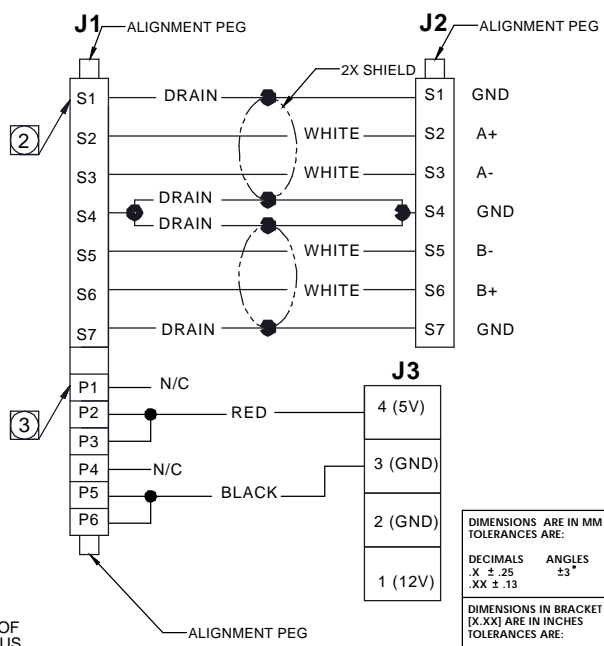

ORDERING NOMENCLATURE :

U709089 - X.XM

5 LENGTH : _____
 (DIM 'A' IN METERS)
 0.5M = 0.5M ± .025M
 1.0M = 1.0M ± .05M

CONSULT FACTORY FOR OTHER LENGTHS

4 USE SERIAL ATA COMPLIANT CABLE, COLOR: RED, 26 AWG, APPROVED SOURCES : HITACHI CABLE MANCHESTER SPACE SHUTTLE DerAn OR CA APPROVED EQUIVALENT

3 REFER TO POWER WIRING DIAGRAM.
2 REFER TO SIGNAL WIRING DIAGRAM.

1. MEETS THE REQUIREMENTS OF DIRECTIVE 2002/95/EC OF THE EUROPEAN PARLIAMENT AND OF THE COUNCIL OF 27 JANUARY 2003 ON THE RESTRICTION OF THE USE OF CERTAIN HAZARDOUS SUBSTANCES IN ELECTRICAL AND ELECTRONIC EQUIPMENT (RoHS).

NOTES : UNLESS OTHERWISE SPECIFIED

DIMENSIONS ARE IN MM TOLERANCES ARE:		APPROVALS		DATE
DECIMALS	ANGLES	DRAWN CUONG P.		06-24-08
.XX ± .25	±3°	CHECKED A.JOCHEN		06-24-08
.XX ± .13		THE INFORMATION AND DESIGN DISCLOSED HEREIN WAS ORIGINATED BY AND IS THE PROPERTY OF CIRCUIT ASSEMBLY CORPORATION. CIRCUIT ASSEMBLY CORPORATION RESERVES ALL PATENT, PROPRIETARY, DESIGN, MANUFACTURING, REPRODUCTION, USE AND SALES RIGHTS THEREETO, AND TO ANY ARTICLES DISCLOSED HEREIN EXCEPT TO THE EXTENT RIGHTS ARE EXPRESSLY GRANTED TO OTHERS. THE FOREGOING DOES NOT APPLY TO VENDOR PROPRIETARY RIGHTS.		
DIMENSIONS IN BRACKET [X.XX] ARE IN INCHES TOLERANCES ARE:		SIZE	CODE IDENT NO.	DRAWING NO.
DECIMALS	ANGLES	C	52072	U709089
.XX ± .010	±3°	SCALE: 2:1		REV. A
.XXX ± .005		SHEET 1 OF 1		

CIRCUIT ASSEMBLY CORP.	
18 THOMAS ST., IRVINE, CALIFORNIA 92618-2777	
CABLE ASSEMBLY - SATA SERIES	
CA-T13SAHS/07SATA/04PIN-XX.X	
"ROHS COMPLIANT"	

SIZE	CODE IDENT NO.	DRAWING NO.	REV.
C	52072	U709089	A
SCALE: 2:1		SHEET 1 OF 1	